

PART NO.: -	TITLE: DRAWING/ COUNTING BOARD	USED BY:	SCALE: NTS	ORDER NO: -	PACKAGE SHEET: OF
SHEET: OF:		DATE:	DRN BY: Bolton T. DATE: 06/06/12	CUSTOMER: FENCO	

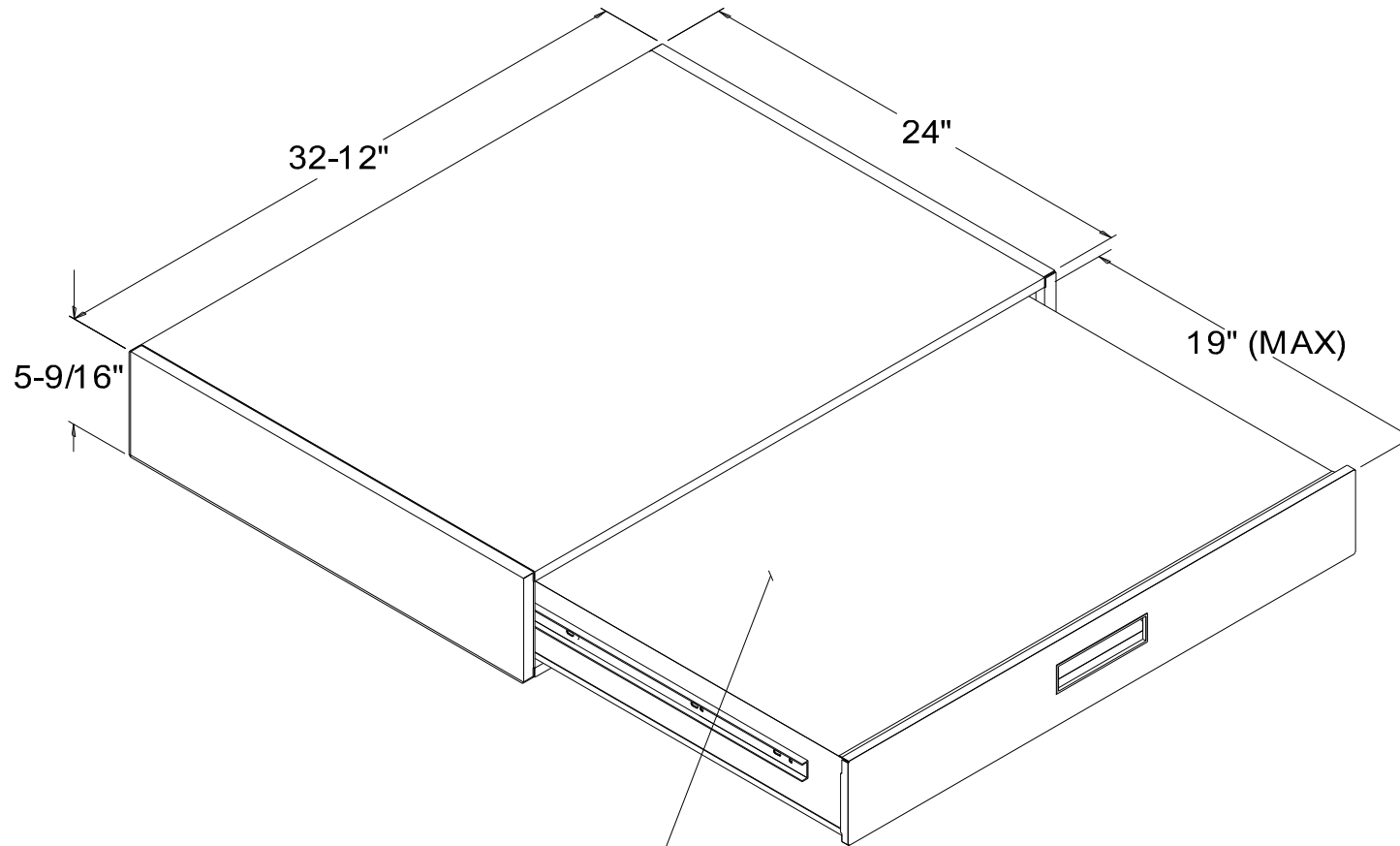

Last Update: 06/06/2012 - Bolton T.

Fenco
 Undercounter & Forecounter Equipment
 P.O. BOX 1238 BURLINGTON, NJ 08016-0516
 www.fencobankequipment.com