

PART NO.:	TITLE:	USED BY: Bolton T.	SCALE: NTS	ORDER NO: -	PACKAGE SHEET: OF
SHEET: OF:	269- 19	DATE:	DRN BY: Bolton T. DATE: 02/05/09	CUSTOMER: FENCO	

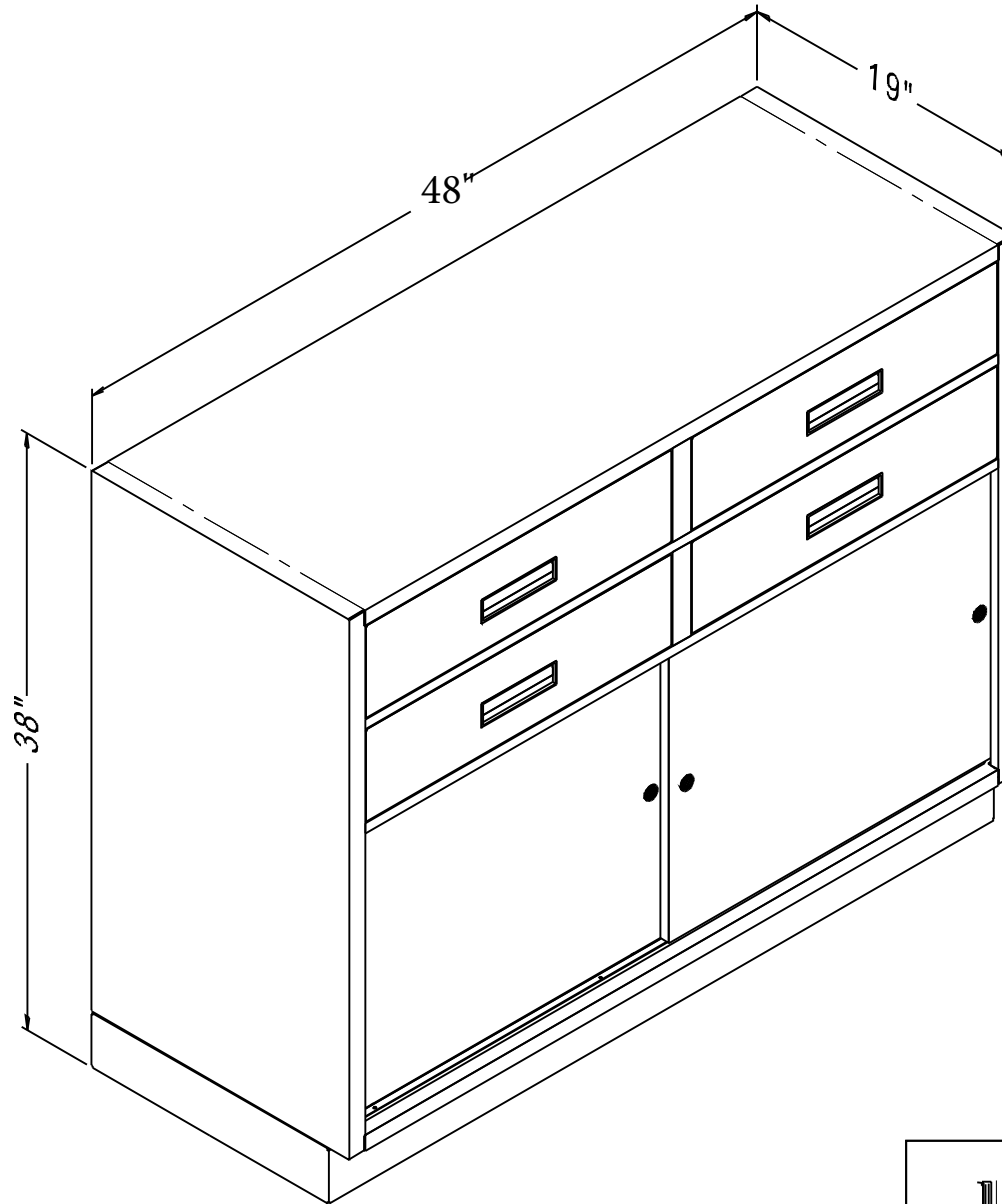

Last Update: 02/05/2009 - Bolton T.



**Fenco**  
 Undercounter & Forecounter Equipment  
 P.O. BOX 1238 BURLINGTON, NJ 08016-0516  
[www.fencobankequipment.com](http://www.fencobankequipment.com)