

PART NO.:	TITLE: <b>P-31</b>	USED BY:	SCALE: nts	ORDER NO.:	PACKAGE SHEET: OF:
SHEET: OF:		DATE:	DRN BY: Bolton T. 04/14/04	CUSTOMER: <b>FENCO</b>	

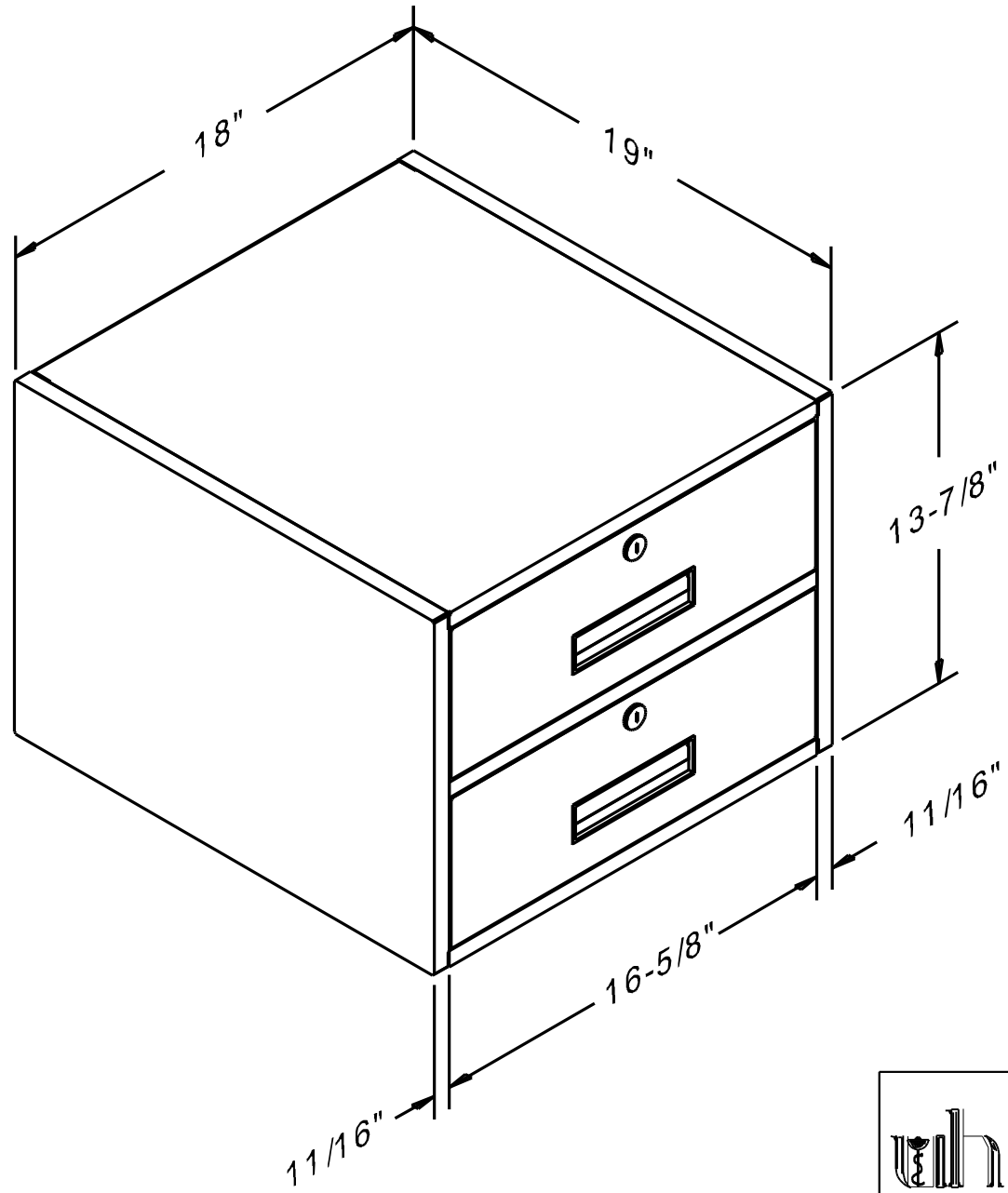

Last Update: 12/11/2007 - Bolton T.

**Fenco**  
 Undercounter & Forecounter Equipment  
 P.O. BOX 1238 BURLINGTON, NJ 08016-0516  
[www.fencobankequipment.com](http://www.fencobankequipment.com)