

PART NO:	TITLE:	USED BY:	SCALE:	ORDER NO.	PACKAGE SHEET: OF
SHEET: OF	BUS - 587	DATE:	DRN BY: BOLTON T. DATE: 02/09/05	CUSTOMER: FENCO	

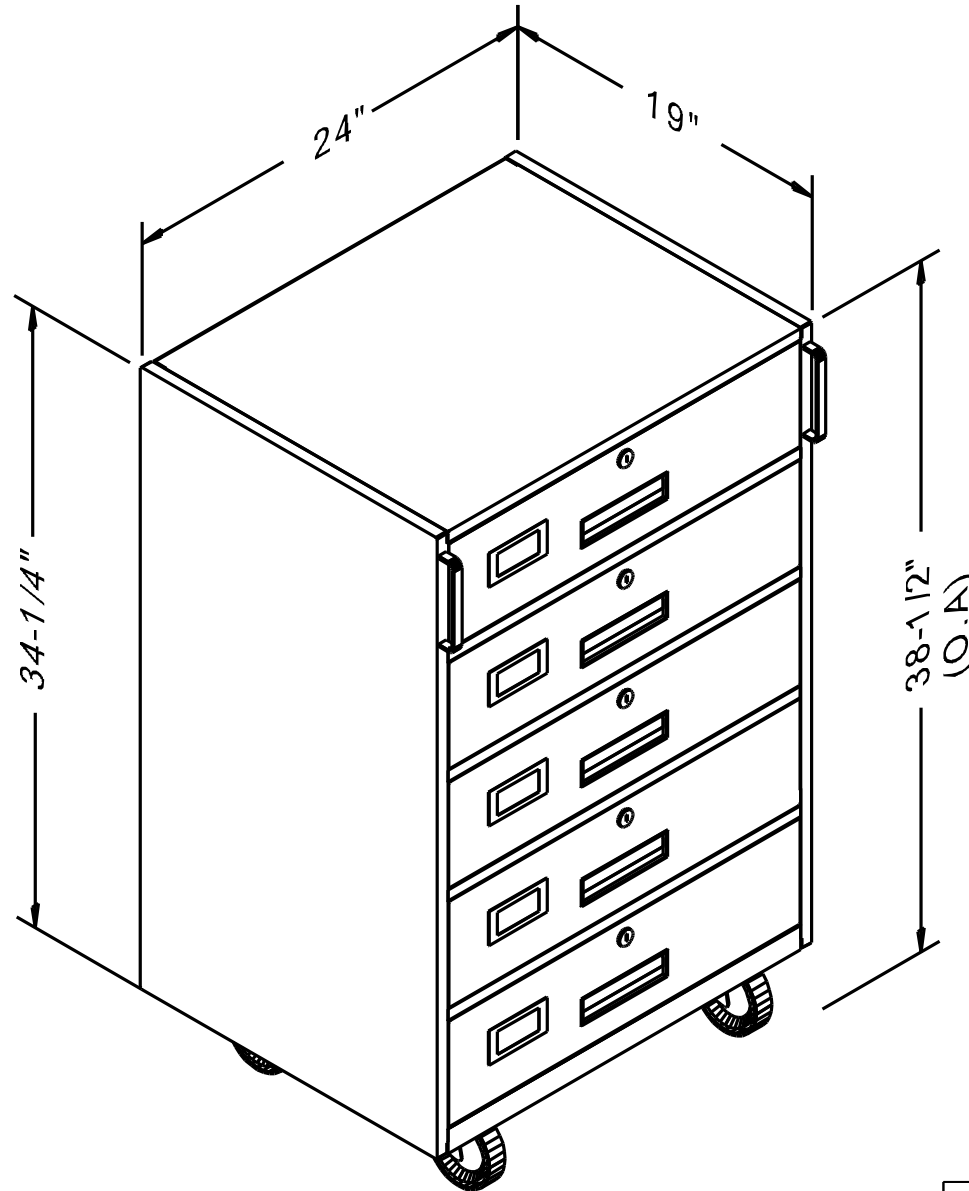

Last Update: 12/11/07 by Bolton T..

Fenco
 Undercounter & Forecounter Equipment
 P.O. BOX 1238 BURLINGTON, NJ 08016-0516
 www.fencobankequipment.com