

PART NO.:	TITLE:	USED BY:	SCALE: NTS	ORDER NO. -	PACKAGE SHEET: OF:
SHEET: OF:	216-19, 216-19-CPU	DATE:	DRN BY: Bolton T. DATE: 10/06/04	CUSTOMER:	FENCO

**216-19**

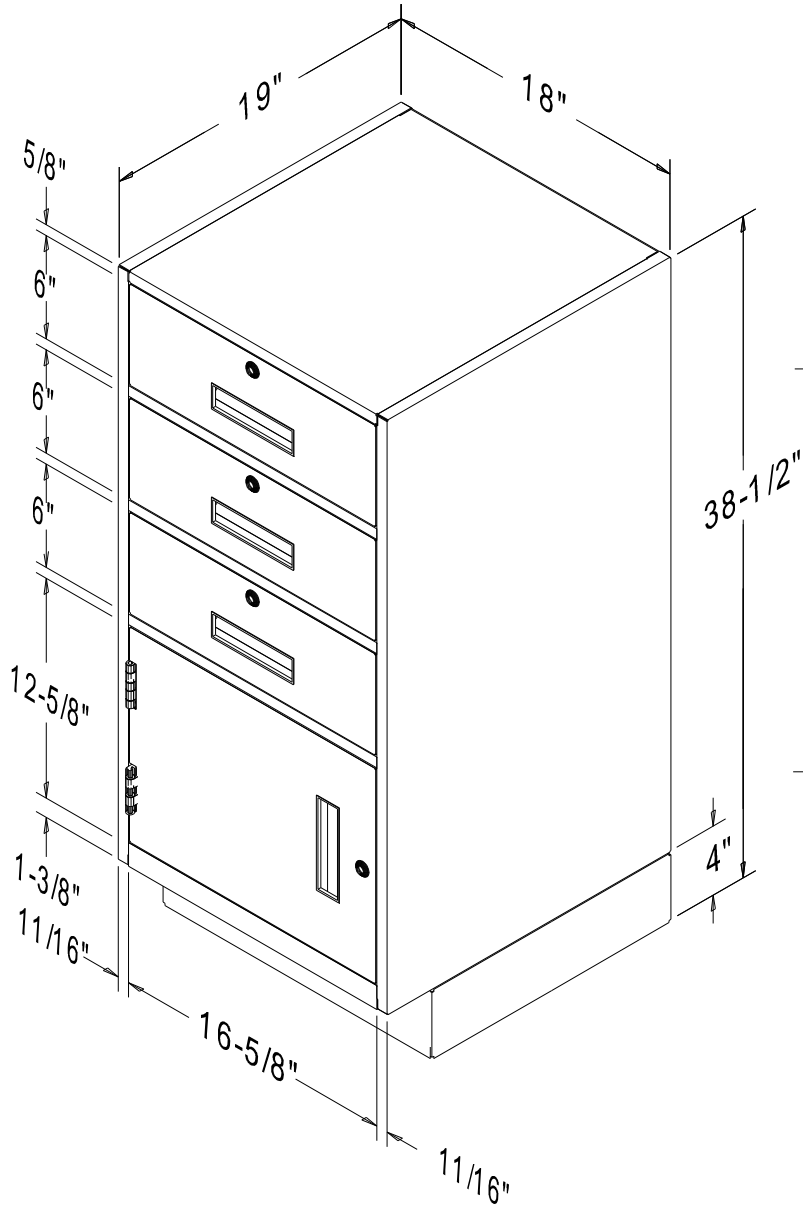

**216-19-CPU**

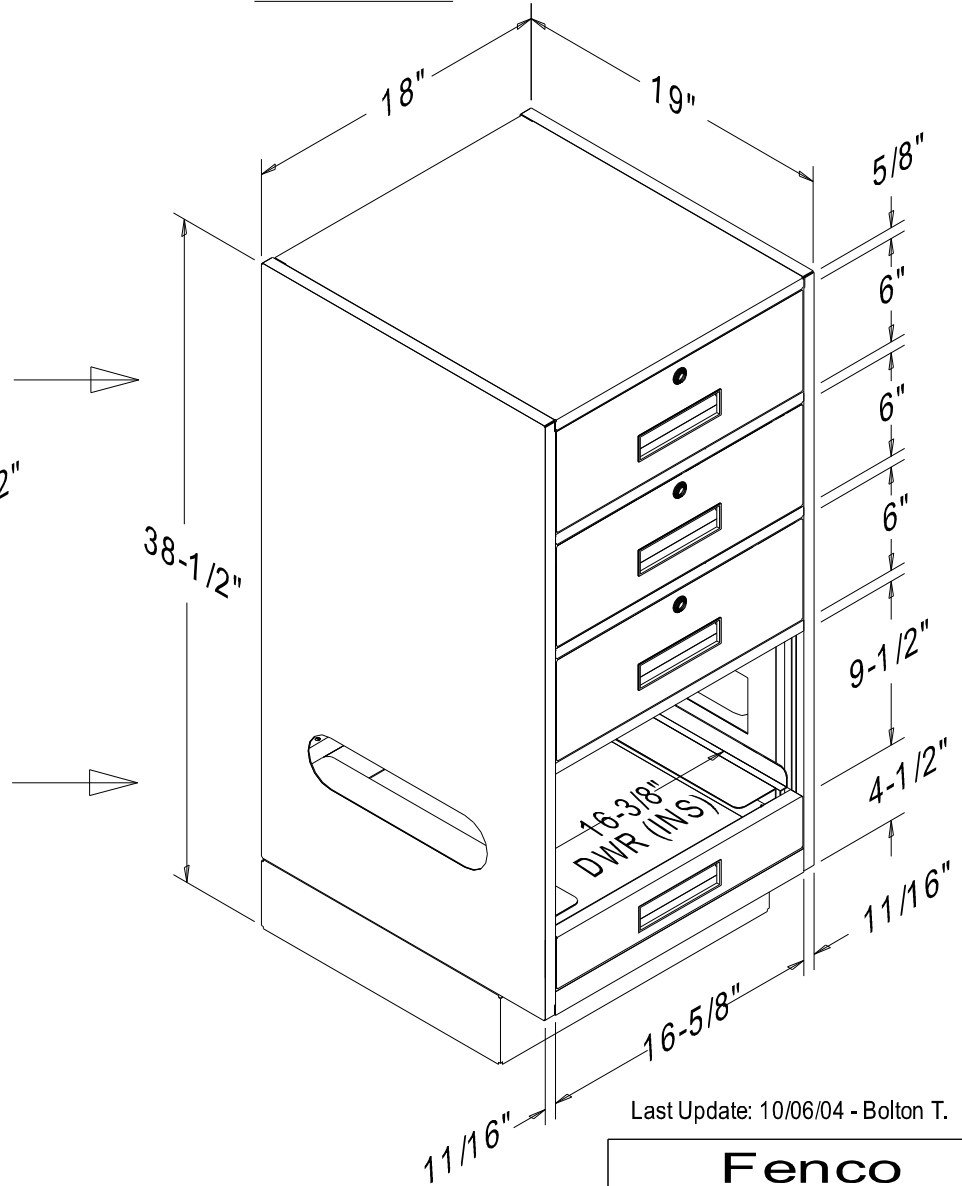

Last Update: 10/06/04 - Bolton T.

**Fenco**  
 Undercounter & Forecounter Equipment  
 P.O. BOX 1238 BURLINGTON, NJ 08016-0516  
[www.fencobankequipment.com](http://www.fencobankequipment.com)