

PART NO.:	TITLE:	USED BY:	SCALE: NTS	ORDER NO:	PACKAGE SHEET:	OF
SHEET: OF:	631-19	DATE:	DRN BY: Bolton T. DATE: 09/05/03	CUSTOMER: FENCO		

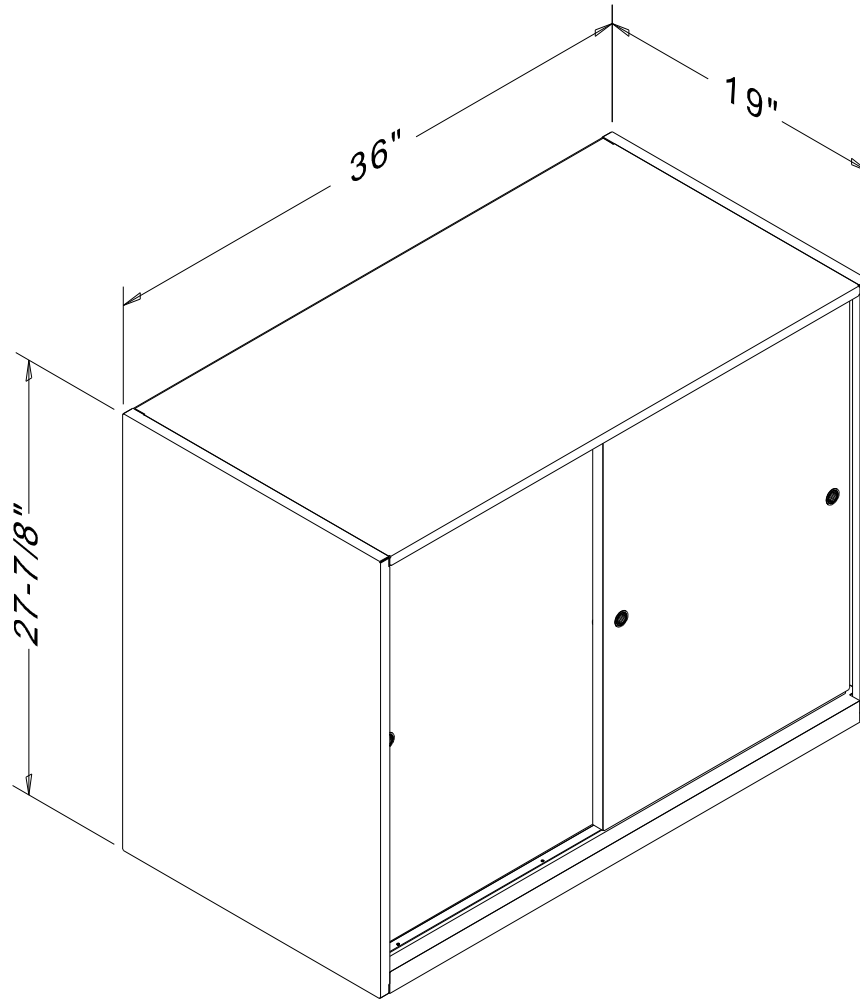

Last Update: 12/11/2007 - Bolton T.

**Fenco**  
 Undercounter & Forecounter Equipment  
 P.O. BOX 1238 BURLINGTON, NJ 08016-0516  
[www.fencobankequipment.com](http://www.fencobankequipment.com)