

PART NO:	TITLE:	USED BY:	SCALE:	ORDER NO. -	PACKAGE SHEET: OF
SHEET: OF	266-19	DATE:	DRN BY: BOLTON T. DATE: 01/15/01	CUSTOMER: FENCO	

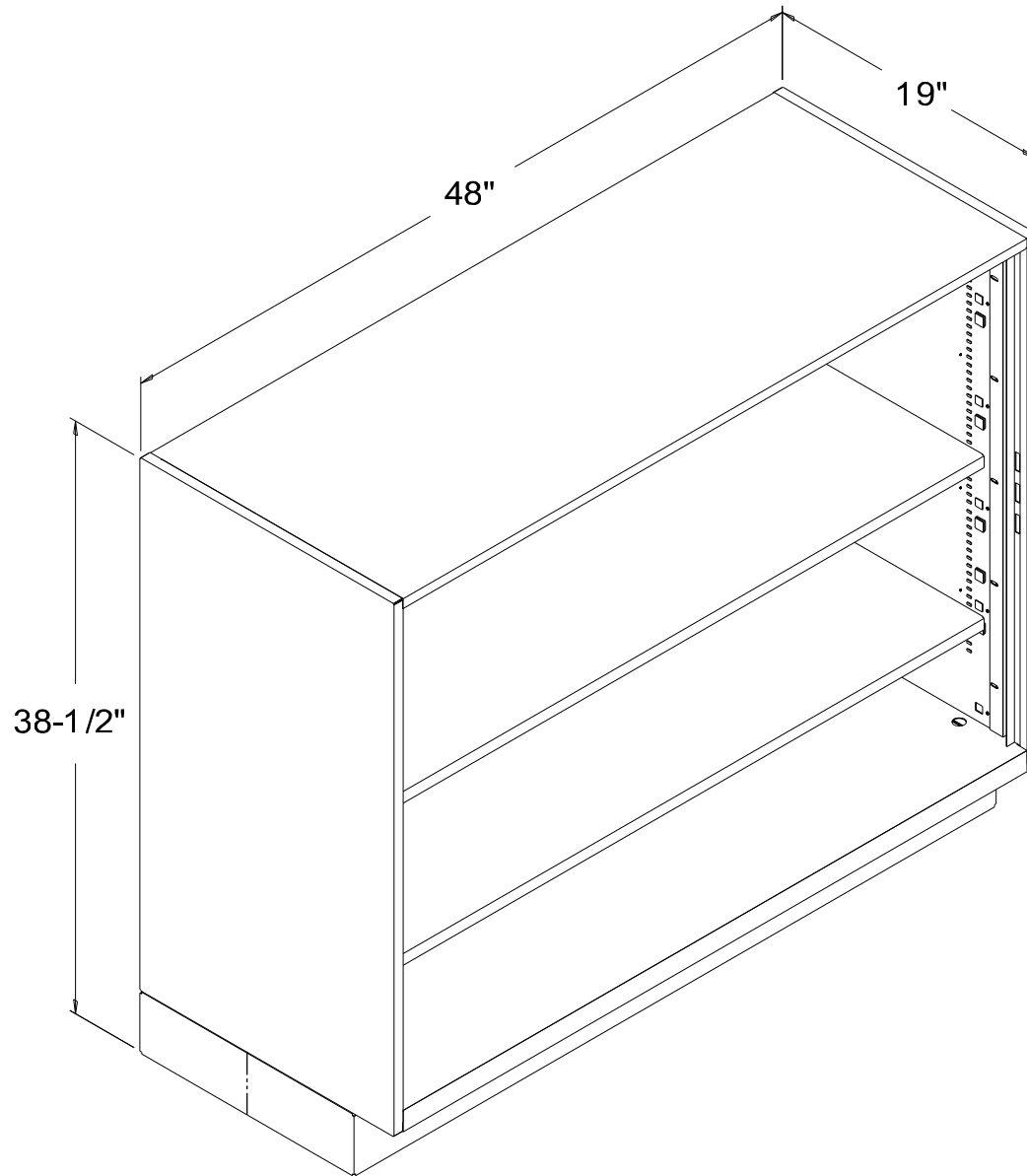

Last Update: 08/23/2006 - Bolton T.

**Fenco**  
 Undercounter & Forecounter Equipment  
 P.O. BOX 1238 BURLINGTON, NJ 08016-0516  
[www.fencobankequipment.com](http://www.fencobankequipment.com)